

SWIMMING POOL DEHUMIDIFIER



FSW63

SERIES

TECHNICAL MANUAL

This manual must be read before use and stored with care.

Respect safety rules.



M.FSW63-04 GB

Index

DECLARATION OF CONFORMITY	4
<i>Dehumidifiers FSW63 series</i>	4
UTILITY AND CONSERVATION OF THE MANUAL	5
GENERAL SAFETY NORMS	5
PERSONAL PROTECTIVE EQUIPMENT	6
UNIT DESCRIPTION	7
FRAME	7
REFRIGERANT CIRCUIT	7
CONDENSER AND EVAPORATORS	7
TUBES	7
COMPRESSOR	7
FANS	7
ELECTRIC BOX	8
MICROPROCESSORS	8
Accessories	8
<i>Electric heaters in inox 2,4 kW 230/1/50 (E.H):</i>	8
<i>Hot water coil (H.W.C) nominal capacity 2,4 kW:</i>	8
<i>3 Way electric valve ON/OFF (E.W):</i>	8
<i>Remote control (humidostat) (On/Off):</i>	8
<i>Autorestart (On/Off):</i>	8
TECHNICAL DATA FSW	9
DRYING CAPACITY	10
PERFORMANCE TABLES FSW63.....	10
FUNCTIONING LIMITS.....	11
CONTROL AND SAFETY DEVICES.....	12
CONTROL DEVICES.....	12
HUMIDITY CONTROL SWITCH.....	12
INSPECTION, TRANSPORT AND SITE HANDLING	13
INSPECTION	13
LIFTING AND SITE HANDLING	13
UNPACKING	13
LOCATION	13
CLEARANCES.....	14

MAINTENANCE AND PERIODIC CHECKS 15

 IMPORTANT WARNINGS 15

CONNECTION OF THE CONDENSED WATER DRAINAGE FITTING AND ELECTRICAL CABLE..... 16

ELECTRICAL CONNECTIONS 17

 Generality 17

 Main supply connection 18

START UP 18

 PRE-START CHECK..... 18

 ELECTRONIC CONTROL AND FUNCTIONING 19

 SIGNALLING PANEL..... 19

 CONTROL PANEL..... 19

GENERAL OBSERVATIONS AND ADVISE 21

DISPOSAL OF THE UNIT AT END OF ITS LIFE 22

TROUBLE SHOOTING 22

 WALL MOUNTING..... 23

 AIR FILTER 23

 UNIT UNDER ALARM 24

ELECTRIC DIAGRAM 25

DIMENSIONAL DRAWINGS FSW 26

DUCTED MACHINE..... 27

DECLARATION OF CONFORMITY



(Community directives Low Voltage and Electro-magnetic Compatibility)

FRAL Company s.r.l. Viale dell'Industria e dell'Artigianato 22/c – 35010 Carmignano di Brenta – PD – hereby declares that the following products:

Dehumidifiers FSW63 series

have been designed, manufactured and distributed according to safety and electro-magnetic compatibility of the European Norms and Regulations:

MACHINES NORMS (2006/42/CE - 17.05.2006) ;
SECURITY REGULATIONS FOR LOW TENSION APPLIANCES 2006/95/CE -
12.12.2006;
ELECTROMAGNETIC COMPATIBILITY (EMC) – 2004/108/CE – 15.12.2004.

It is hereby certified that this Dehumidifier conform to the:
IEC Regulations CEI-EN 60335-2-40, CEI-EN 55014-1, 55014-2.
The machine is built according to RoHS European Norms:
2011/65/UE year 2011 and CEI-EN 50581.

The Legal Agent
Ing. Alberto Gasparini

UTILITY AND CONSERVATION OF THE MANUAL

This Manual conforms to the requirements of the Norms 98/37/CE and subsequent modifications. The Manual gives all necessary indications required for the transport, Installation, start-up and maintenance of the machines, which must be strictly followed by the user for a correct functioning of the same.

To this purpose, the user must also strictly comply with the security norms described in the Manual.

The manual must always follow the machine and must be kept in a place which will guarantee its perfect conservation for the proper use from the operator.

GRAPHIC SYMBOLS AND INDICATIONS INCLUDED IN THE MANUAL:



Shows that ATTENTION must be paid to all procedures and operations to be carried out for ensuring the correct functioning of the machine, describes the operations that must be avoided, and finally informs the operator about the correct procedure and operations to be followed for the proper use of the machine.

GENERAL SAFETY NORMS

When installing or servicing the unit, it is necessary to strictly follow the rules reported on this manual, to conform to all the specifications of the labels on the unit, and to take any possible precautions of the case for workers.

Pressure in refrigerant circuit and electrical equipment present in the unit can be hazardous when installing or servicing the unit

Therefore, all operations on the unit must be done only by trained people.



The machine is IPX2 and it must be installed according with local norms and laws of the place of installation.



Not observing the rules reported on this manual, and every modification to the unit done without explicit previous authorisation, will cause the immediate termination of the warranty.



Attention: before every operation of servicing on the unit, be sure that the electric supply is disconnected.



Close to the unit a switched electrical plug must be present, according with local laws and norms.



Main supply must be protected with a differential switch, according with local laws and norms.



Never modify settings of the safety devices.







Never sprinkle water over the unit and its electrical components.



It must not be used under explosive atmosphere



PERSONAL PROTECTIVE EQUIPMENT

When operating and maintaining the FSW unit, use the following personal protective equipment.

	<p>Equipment: people who make maintenance or work with the unit, must wear an equipment in accordance with the safety Directives. They must wear accident prevention shoes with anti-slip sole where the paving is slippery.</p>	
	<p>Gloves: During the cleanings and the maintenance operations, it's necessary the use of appropriate gloves. In case of gas recharge, It's compulsory the use of appropriate gloves to avoid the rick of freezing.</p>	
		<p>Mask and goggles: Respiratory protection (mask) and eye protection (goggles) should be used during cleaning and maintenance operations.</p>

SAFETY SIGNS

The equipment features the following safety signs, which must be complied with:

	<p>General hazard</p>
	<p>Electric shock hazard</p>

UNIT DESCRIPTION

FRAME

All FSW units are made from galvanised thick sheet metal, painted with polyurethane powder enamel at 180°C to ensure the best resistance against the atmospheric agents. The frame is self-supporting

REFRIGERANT CIRCUIT

The refrigerant gas used in these units is R410a. The refrigerant circuit is made in according to ISO 97/23 concerning welding procedures and PED regulation.

The refrigerant circuit includes:

- filter drier.
- schrader valves for maintenance and control.
- capillary expansion.
- compressor.

CONDENSER AND EVAPORATORS

FINNED PACK

It consists of copper tubes mechanically expanded into aluminium or copper fins provided with full collars that allow their regular spacing. The best heat transmission is guaranteed by the fin collars that completely cover the tubes.

FINS

They are manufactured by high precision pressing of aluminium, aluminium epoxy painted, copper or pretinned copper sheets. The fin shape is slightly corrugated in order to improve the heat exchange transmission coefficient without heavily affecting the air pressure drop. Furthermore a good water draining is assured and the inside dust accumulation is avoided.

TUBES

For the heat exchangers high quality copper tubes are used. The tubes are suitable for the majority of the primary refrigerants in both cold and warm working conditions.

COMPRESSOR

The compressor is rotative type.

The characteristics of the compressor are the following:

1. High efficiency for saving energy consumption
2. Low sound level, quiet operation
3. Applied HFC refrigerant for protecting environment
4. High reliability, long lifetime.

FANS

Centrifugal fan type.

ELECTRIC BOX

The electric switch board is made according to electromagnetic compatibility norms (2004/108 CEE) and Electrical Safety Rules for the Low Tension Appliances 2006/95 CEE.

Inside the electric box there are the following components:

1. Terminals for remote control;
2. Electronic board;

The installation must provide a general switch if necessary, according with local laws and norms.

MICROPROCESSORS

The microprocessors check all the function of the machine like: General functioning, automatic defrost system, alarms and set point of the humidity and temperature (temperature only for machine with hot water coil Version).

Accessories

Body machine completely in Inox

Electric heaters in inox 2,4 kW 230/1/50 (E.H):

Armored electric heaters in inox, it is able to transfer the 90% of the convective heat in way evenly.

Hot water coil (H.W.C) nominal capacity 2,4 kW:

This battery can help you in heat the environment of the swimming pool thanks its efficient water hot coil due to the narrow step fins.

3 Way electric valve ON/OFF (E.W):

Control of the flow water inside the hot water coil

Remote control (humidostat) (On/Off):

It is possible to use a remote control with the machine. In this case must be used a remote humidostat to be connected to the terminal boxes of the electric panelboard in place of the standard humidostat. It is also possible to have an ON-OFF switch to be electrically connected in series to the humidostat.

Autorestart (On/Off):

If is ON State network fails or machine is unplugged, the values of set point, delay counter, defrost counter, hour counter and any other operating parameters are stored and, when power comes back, everything continues as before.

TECHNICAL DATA FSW

Mod.		63
Indez Protection (IP)		IPX2
Drying capacity ⁽¹⁾	L/24h	63
Nominal power consumption ⁽³⁾	kW	0,7
Maximum power consumption ⁽⁴⁾	kW	0,95
Max.current consumption ⁽⁴⁾	A	4,4
Nominal Air flow	m3/h	600
Available static pressure	Pa	40
refrigerant charge	Kg	R410a
Sound pressure level ⁽⁵⁾	dB(A)	49
Temperature operating range	°C	5 ÷ 35
Humidity operating range	%	45 ÷ 99
Condensate draining connection	INCH''	¾''
Width	mm	1008
Depth	mm	221
Heigth	mm	602
Operating weight	Kg	48
Nominal power supply	V/ph/Hz	230 /1 +N/50

(1) Referred to: inlet air temp. 32 °C relative humidity 90%.

(2) Referred to: inlet air temp. 26°C outside temp. 30°C.

(3) Referred to: inlet air temp. 26,7 °C relative humidity 60%.
Without electric heater.

(4) Referred to: inlet air temp. 35 °C relative humidity 70%.
Without electric heater.

(5) Sound power level calucated in 3m free field.

DRYING CAPACITY

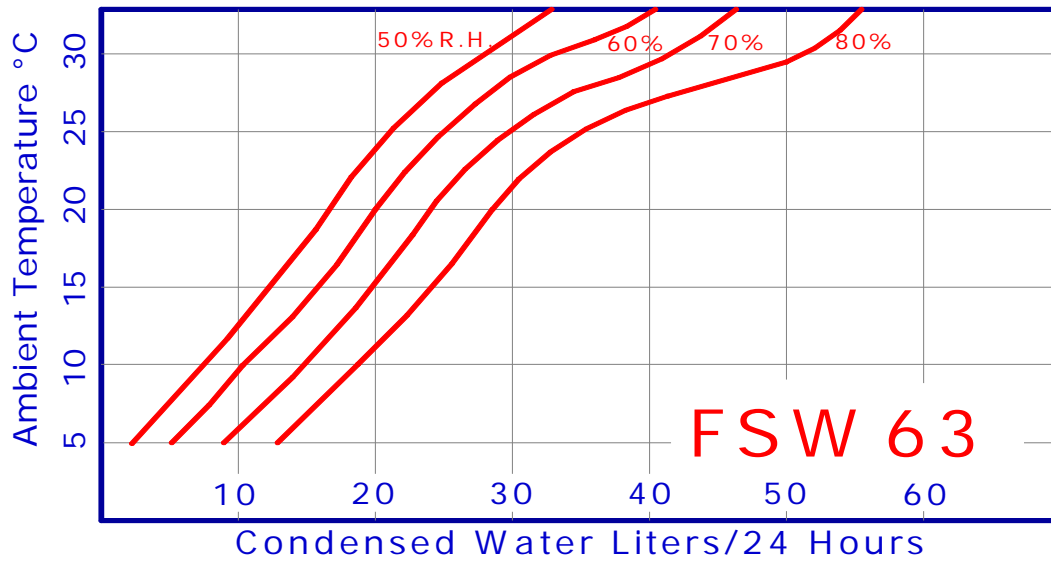

PERFORMANCE TABLES FSW63

CONDENSED WATER AT DIFFERENT ROOM TEMPERATURE AND HUMIDITY CONDITIONS			
Room condition	Condensed water	Room condition	Condensed water
10°C-60%	10 l/24h	25°C-60%	25 l/24 h
10°C-80%	18 l/24h	25°C-80%	35 l/24 h
15°C-60%	15 l/24 h	27°C-65%	28 l/24 h
15°C-80%	23 l/24 h	27°C-80%	39 l/24 h
20°C-60%	20 l/24 h	30°C-80%	52 l/24 h
20°C-80%	28 l/24 h	32°C-90%	63 l/24 h

FUNCTIONING LIMITS

Following Diagram represents FSW units application .



It is strongly recommended to let the units operate within the below reported limits. Exceeding these limits it is not granted neither normal operation nor unit reliability and integrity (for special applications, please contact our Company).

Operating Table – standard units

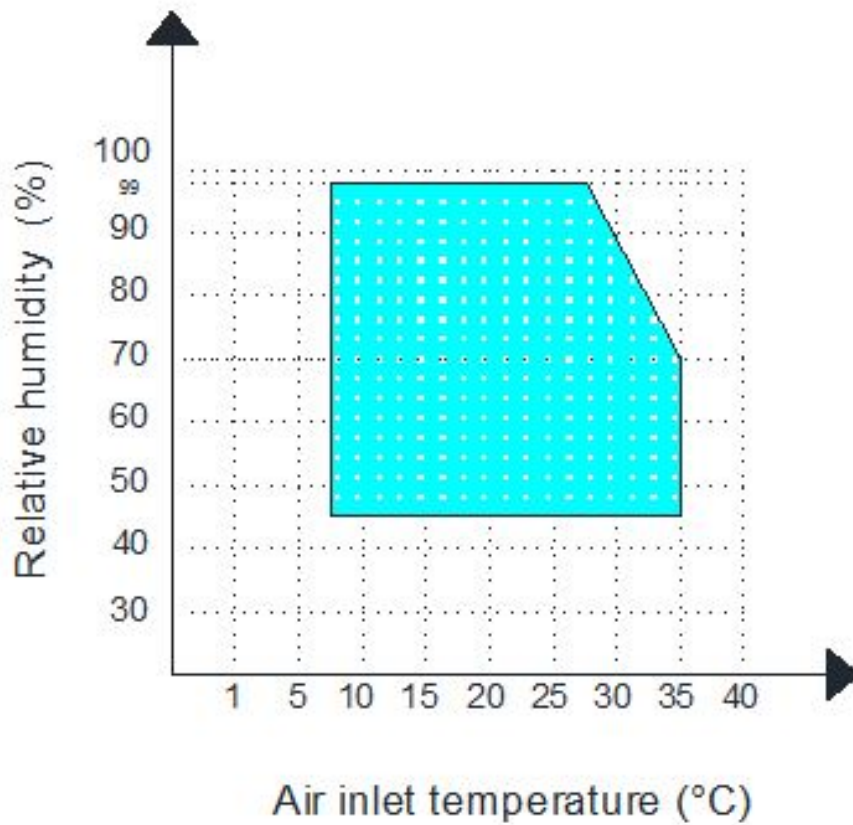

CONTROL AND SAFETY DEVICES

CONTROL DEVICES

All the control devices are tested on factory before the unit is delivered.
Their operating mode is described in the following paragraphs.

HUMIDITY CONTROL SWITCH

Humidity control switch enables or disables unit operation depending on the humidity value desired.
To verify its correct operation, set the humidity desired value close to lower limit. At this point verify that fan and compressor (after a time delay) will be started in sequence. Verify as well that the unit is stopped when humidity set is reached.

INSPECTION, TRANSPORT AND SITE HANDLING

INSPECTION

After receiving the unit, immediately check its integrity. The unit left the factory in perfect condition; **any eventual damage must be questioned to the carrier and recorded on the Delivery Note before it is signed. Our firm must be informed, within 8 days, of the extent of the damage. The Customer must prepare a written statement of any severe damage.**

LIFTING AND SITE HANDLING

The lifting is obtained by using a forklift: fork must be inserted in the base pallet, and care must be taken in order that the fork does not hit the section base or panel (see the picture below).

To unload the unit with a crane, pass bars under the machine and attach the necessary cable or chain lifting devices to the bar, ensuring that they are clamped firmly; protect the sides of the chiller with boarding or material of a similar nature.

UNPACKING

When unpacking the unit pay attention not to damage the unit. The package is made up by different materials: wood, paper, nylon etc. It's a good rule to keep them separately and deliver to the proper collecting centre in order to reduce their environmental impact.

LOCATION

Consideration must be given to the following points when determining the most suitable site for the unit installation:

- ✓ location arrangement in order to guarantee adequate air flow (no narrow spaces)
- ✓ electrical power supply location;
- ✓ accessibility for servicing/maintenance and repair of the unit and/or its components;
- ✓ floor loading strength and ability to support the operating weight of the unit;
- ✓ possible objection to operating noise.



The machine respects the previous declaration of conformity only if it's resting on the ground. If the machine is fixed to the wall it's necessary to install a plate in order to respect the declaration of conformity. This plate must be ordered on demand.

CLEARANCES

Absolute care must be taken to ensure adequate air volume to the air intake and fan discharge, and to avoid air recirculation through the unit that will deeply reduce its performances.

For these reasons it is necessary to observe the following clearances (see the pictures in the following pages):

- air filter suction side: 1 metre min.
- top side: 1 metre min

FOR USE IN SWIMMING POOLS KEEP DISTANCES FROM WATER ACCORDING WITH SAFETY NORMS (MACHINE IS IPX0)



MAINTENANCE AND PERIODIC CHECKS

IMPORTANT WARNINGS



WARNING: Inside the unit some moving components are present. Be very careful when operating in their surroundings even if the electric supply is disconnected.



WARNING: The unit should be installed so that maintenance and/or repair services be possible. The warranty does not cover costs due to lifting apparatus, platforms or other lifting systems required by the warranty interventions.



WARNING: The top shell and discharge line of compressor are usually at high temperature level. Be very careful when operating in their surroundings.

WARNING: Aluminium coil fins are very sharp and can cause serious wounds. Be very careful when operating in their surroundings.



WARNING: After servicing operation close the unit with cover panels, fixing them with locking screws.



All this operation described in this chapter **MUST BE DONE BY TRAINED PEOPLE ONLY**



Before every operation of servicing on the unit, be sure that the electric supply has been disconnected.



In the inner side of the unit movable parts are present. Be very careful when operating in their surroundings.



Aluminium coil fins are very sharp and can cause serious wounds.



Be very careful when operating in their surroundings.



After servicing operations, close the unit with cover panels, fixing them with locking screws.

CONNECTION OF THE CONDENSED WATER DRAINAGE FITTING AND ELECTRICAL CABLE

Connect condensed water drainage fitting ($\frac{3}{4}$ " M) to a draining pipe.

It should be always avoided to form a double siphon, which could obstruct the water flowing with the consequent risk of flooding the area.

Removing the case in order to insert the pipe and electrical cable like represented here below.

1 Unscrew casing's screw.



2 Remove the casing.



3 Spin condensation pipe.



4 Remove plastic cover.



5 Connect power and remote humidostat wires.



ELECTRICAL CONNECTIONS

Generality



This machines series belongs to the electric appliances functioning at low tension (230 V).



Before every operation on the electric section, be sure that the electric supply is disconnected.



Main supply must be protected with a differential switch



Close to the unit a main switch must be present.

It must be verified that electric supply is corresponding to the unit electric nominal data (tension, phases, frequency) reported on the label in the front panel of the unit.
Power connections must be made using a three-wire cable + neutral wire + ground cable.



Power cable and line protection must be sized according norm and laws according with absorbed current of the machine (see technical data).



The line voltage fluctuations must not be more than $\pm 5\%$ of the nominal value, while the voltage unbalance between one phase and another must not exceed 2%. If those tolerances should not be respected, please contact our Firm to provide proper devices.



Electric supply must be in the limits shown: in the opposite case warranty will terminate immediately.



Electrical connections therefore must be always done according to the instructions reported on the wiring diagram enclosed with the unit and norms and laws.

Ground connection is compulsory. Installer must connect ground cable with a dedicated terminal on the apposite terminal block.

Main supply connection

The Electric Power Supply Connection must be carried out according to the indications given in the Electric Diagram, by connecting the cable supplied with the machine and according with safety norm.

Models Fsw63 must be electrically powered with 1 phase-neutral-earth.

Remote humidistat connections

Remote humidistat connection must be realised according with electric diagram.
Connections must be done according to the electric wiring diagram specifications.

START UP

PRE-START CHECK



Check that all power cables are correctly connected and all terminals are fastly fixed.



The voltage at the phase, must be the one indicated on the unit label $\pm 5\%$ tolerance. If this should not happen, please, contact our Factory.



Caution: before proceeding to start up, check that all the cover panel be located in the proper position and locked with fastening screws.



For temporary stop (night-time, weekend, etc.) never break the power supply and strictly follow the procedures illustrated at paragraph 4.6

ELECTRONIC CONTROL AND FUNCTIONING

The electronic board installed on the model FSW63 is connected directly to the power outlet of the machine. It is equipped with three temperature probes and a humidistat.

The electronic control unit, by means humidistat that measures the relative humidity in the environment, makes the machine works in order to achieve the degree of humidity wanted.

When the temperature reached by the finned coil is too low the electronic control unit starts a defrost cycle to melt the ice formed in the finned coil.

This unit is programmed to stop the dehumidifier if the temperature drops below 4.5 ° C.

SIGNALLING PANEL

Units are provided with signalling light panel that indicates unit operational status. Below is reported a brief description of their meaning.



CONTROL PANEL

The Electronic card with microprocessor, control many functions:



Heat led; when the heating function is activated, the LED pulses every 10 seconds, when the heating element is powered the LED remains lit.



Power LED; it's on when the machine is in the ON state.



Alarm LED; it's on when an alarm comes on. It turns off if the alarm is reset.



RUN

Run LED; the LED is on when the compressor is running, blinks when the dehumidifier is waiting to restart or is in defrost. It's switched off when, in the ON state, the set of desired humidity has been reached.



FULL

Full LED; this LED is lit when the condensate tank is full. When PUMP function is activated it blinks every 10 seconds.



REMOTE

Remote Function LED; the machine has the possibility of using a remote humidistat or switch. For this purpose, it needs to change the set in the PCB: with plug inserted in the socket, put the machine in OFF position, then press all together these 3 buttons for 4 seconds: HOUR COUNTER, SET UP and SET LOW , the machine changes and led REMOTE turn on. Pay attention that if the humidity is set in cont position, machine works not considering the remote control.

Remote LED; lights up when the machine is controlled remotely.



HEAT

ON/OFF (Only for machines with Electrical heaters or Way valve); When the machine is ON, you can activate the heating function by pressing and holding the button HEAT for 4 seconds. Same procedure to disable it.



POWER

ON/OFF function; plugged into the outlet (with ground wire!), the display turns on and shows the relative humidity in the room.

The machine is in the OFF state when the Power LED is off. It's in the ON state when the Power LED is on.

When OFF, to switch on the dehumidifier, simply press the POWER key and depending on the relative humidity set the machine starts working.

When the machine reaches the level of required moisture goes into stand-by mode: automatically stops but remains in the ON state (POWER LED on).

If the humidity goes above the set point the dehumidifier starts again.

When ON to put the dehumidifier in OFF just press the POWER button (the display continues to indicate the humidity in the room).

Note: putting the machine OFF and immediately ON, the compressor does not start immediately and the Run led starts to flash. After a time of 210 seconds the machine restarts.



HUMIDITY/TEMPERATURE SET function; press one of the SET-/ +: the display starts flashing to indicate the humidity set; continuing to press SET-/ + you can bring to the set of required moisture (from 30% to 80%). After 4 seconds the display stops flashing and the new set of moisture is detected by the control unit.

It's possible to make the machine works regardless of the degree of moisture holding SET- until the message "Cont" appears.

(Only for machines with Electrical heaters or Way valve) When the heating mode is activated by pressing the key HEAT once is possible to display the temperature in the environment (eg t22 ° means that in this environment is a temperature of 22 ° C). To change the set temperature press the key HEAT and immediately after the SET-/+: the display starts flashing to indicate the set temperature previously set and continuing to press the SET-/ + it's possible to reach the required temperature (from 15°C to 32°C). After 4 seconds the display stops flashing and the new set temperature is detected by the control unit.



HOUR COUNTER: per visualizzare le ore di funzionamento è sufficiente premere il tasto HOURS.



PUMP BUTTON: in the OFF state, press at the same time SET + and PUMP for 4 seconds. The message "PunP" appears on the display and Full LED flashes every 10 seconds. Same procedure to return to the tank mode operation.

GENERAL OBSERVATIONS AND ADVISE

It is a good rule to carry on periodic checks in order to verify the correct working of the unit:



Check that safety and control devices are working correctly (monthly).



Make sure that all the terminals on the electric board and on the compressor be well locked. Periodic cleaning of the sliding terminals of the contactors should be done: if any damage is found, please replace the contactors (monthly).



Make sure that there is no oil leakage from compressor (monthly).



Check that the electric resistance in the compressor crankcase be properly functioning (monthly: low temperature units only).



Clean draining pan and pipeline (monthly).



Clean finned coils filters with compressed air in the opposite direction of the airflow. If filters should be fully clogged, clean them with a water jet to be sprayed against the air flow side(monthly or more frequently if the unit operates on a dusty environment).



Check mounting of fan blades and their balancing (every 4 months).

POWER SAVINGS

To reduce power consumption, take care of following suggestions :



Make sure that room in which unit should operate has doors and windows firmly closed;



Set the humidity control switch to the proper value: lower set values than necessary (even few points) may cause great capacity loss with consequently longer operating periods: it is advisable to set humidity values below 60% only if strictly necessary.



For the machine which has a second condenser (monoblock or split system) check every month if the heat exchanger is clean and free from room dust, and check the efficiency of the motorfan.

DISPOSAL OF THE UNIT AT END OF ITS LIFE

Once the unit is arrived at the end of its life and needs to be removed or replaced, the following operations are recommended:



The unit refrigerant has to be recovered by trained people and sent to proper collecting centre;



Compressor lubricating oil has to be recovered and sent to proper collecting centre;



the frame and various components, if no longer usable , have to be dismantled and subdivided according to their nature; in particular, copper and aluminium, which are present in conspicuous quantity in the unit.

These operations allow easy material recovery and recycling process, reducing environmental impact. It is recommended to follow the pertinent norms in the disposal of the wasted materials.

TROUBLE SHOOTING

In the following pages are reported the most common troubles that can cause the unit to stop or to operate in an uncorrect way.



Concerning the solutions, it is necessary to take an extreme care on the actions to adopt: an excessive confidence may cause serious accidents to inexperienced people. It is advisable, once the cause is detected, to contact our servicing people or trained people only.

WALL MOUNTING

Please look the picture here below in order to understand like to mount the machine on the wall, there are two holes behind the machine that can be used for hanging the machine on the wall with the correct screws for the support of the machine



AIR FILTER









UNIT UNDER ALARM

When red light is lit up, the unit is stopped and set under alarm condition.



To restore normal operating mode, it is necessary to detect and remove the cause of the alarm

PROBLEM	PROBABLE CAUSE and CORRECTIVE ACTION
 FULL + "FULL"	Tank is full. The alarm resets automatically emptying the tank.
 ALARM + "Lo t"	It occurs for two possible reasons: the environment temperature is too low or the defrost cycles are not able to melt the ice in the battery. To reset put the dehumidifier above 10 ° C, if not reset put the dehumidifier off with POWER button and unplug the machine.
 ALARM + "LoPt"	Possible lack of gas in the circuit. The alarm resets automatically after 210 seconds. If the alarm does not reset simultaneously press and SET HOURS + for 10 seconds. If the problem occurs again, call for service.
 ALARM + "HI t"	Combination of temperature and humidity too high. The alarm resets automatically when the temperature drops.
"Prob"	Malfunction humidostat. In any case, the machine continues to operate. Contact the service to replace the humidistat.
 ALARM + "Pro1" o "Pro2" o "Pro3"	Malfunction of one of the three temperature probes. The dehumidifier goes into stand-by mode. Contact the service to replace the probes.
 FULL + "PunP"	The internal alarm of pump is ON (for machines with pump). The alarm is reset when the pump switch is closed.

ELECTRIC DIAGRAM

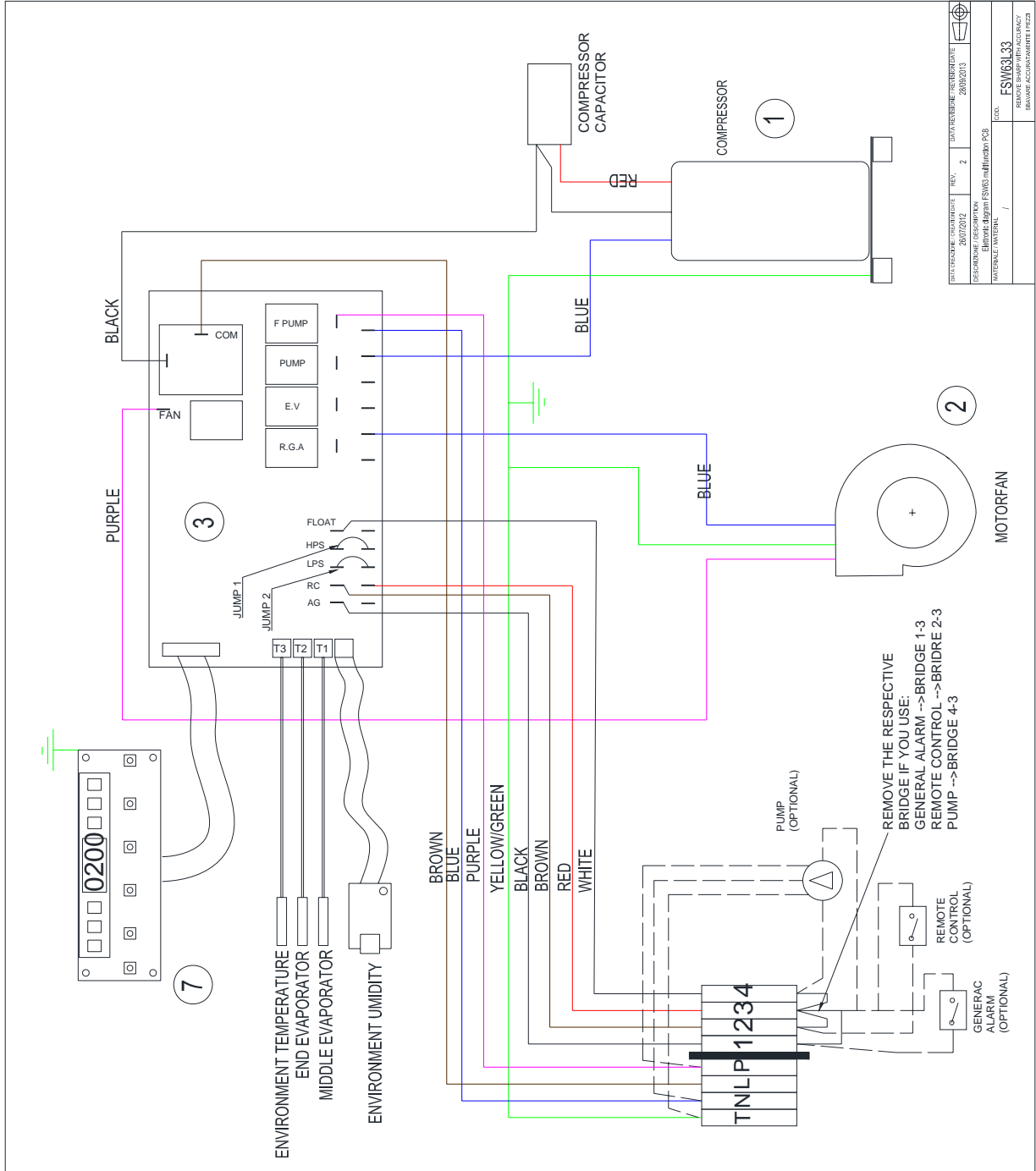

DIMENSIONAL DRAWINGS FSW

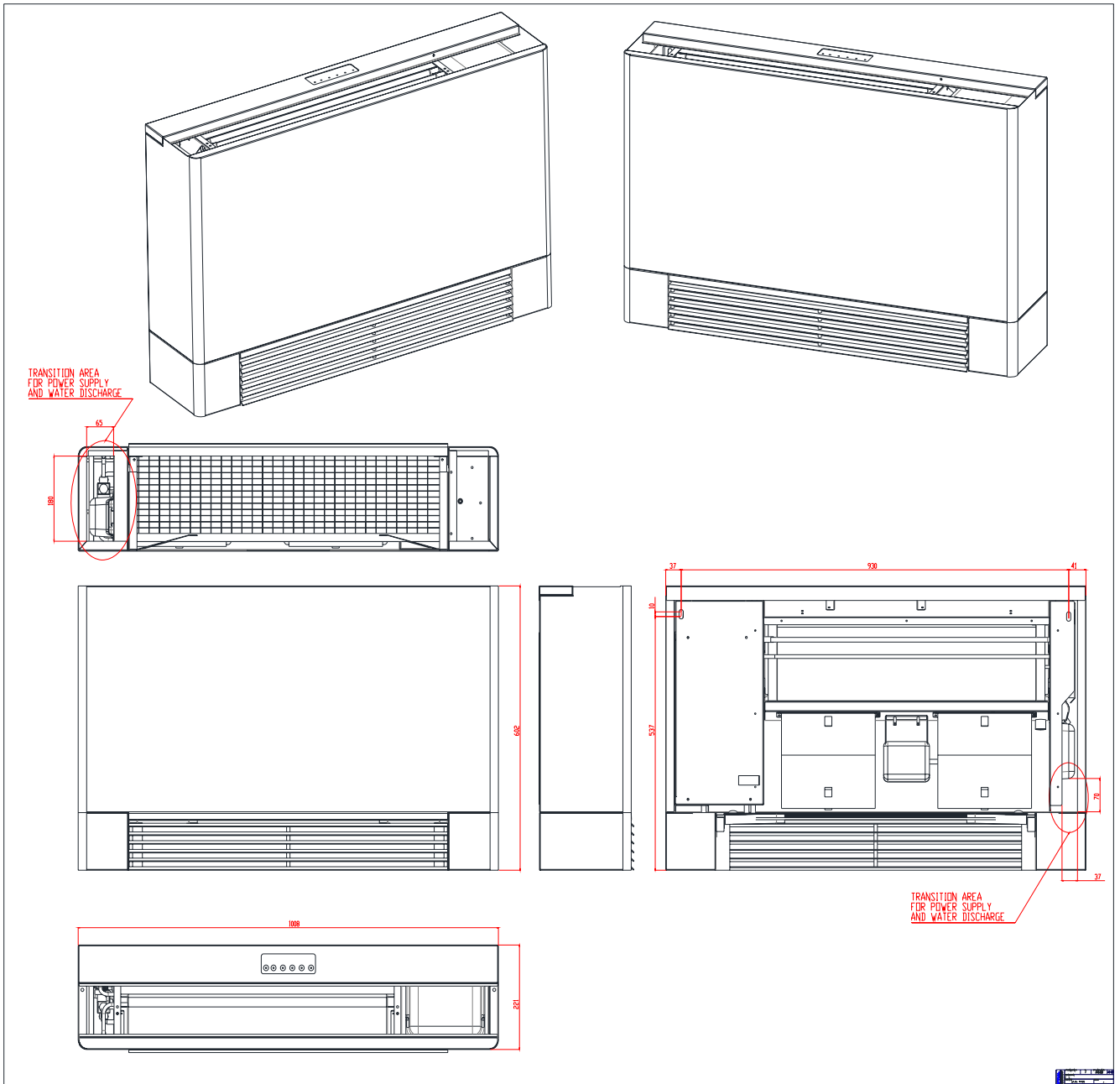

DUCTED MACHINE

It's possible to require a ducted version of the machine.

